

## DESIGN FEATURES

- Built-in ISO 5211 Mounting Pad Easy Automation
- Fire Safe Design Approved
- Anti-static Devices for Ball-Stem-Body
- Blow-out Proof Stem
- Pressure Balance Hole in Ball Slot
- NACE MR-0175 (Optional)
- Casting Approved by TÜV AD 2000-Merkblatt W0

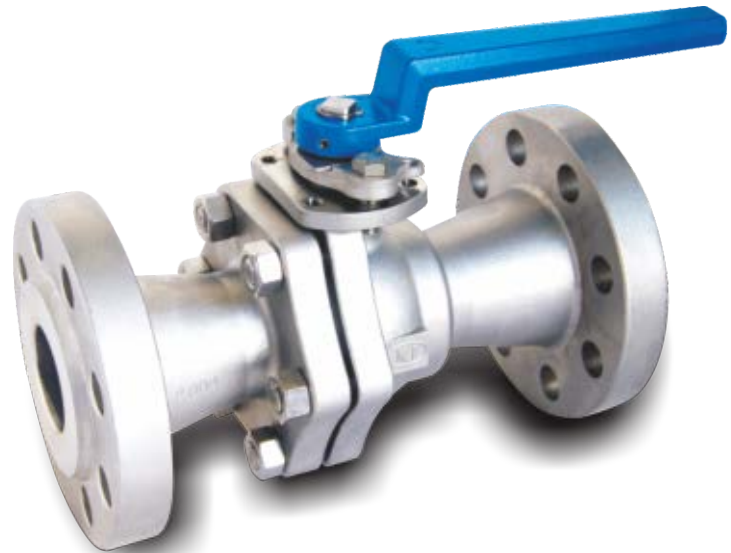

## APPLICABLE STANDARDS

- Design Standard : ASME B16.34
- Frie Design : API 607 5<sup>th</sup> 2005, ISO10497
- Face To Face : ASME B16.10
- Flanged End : ASME B16.5 Class 600
- Inspection & Testing : API 598

## TORQUE VALUES

Close to Open Torque at Various Differential Pressure ( $\Delta P$ ), Standard Seats (TFM4215)

Size\ $\Delta P$	75psig		150psig		300psig		700psig		1000psig		1500psig	
	N-m	In-lb	N-m	In-lb	N-m	In-lb	N-m	In-lb	N-m	In-lb	N-m	In-lb
NPS												
1/2	7	62	7	62	7	62	7	62	7	62	7	62
3/4	8	71	8	71	8	71	8	71	8	71	8	71
1	13	115	13	115	15	133	15	133	15	133	15	133
1 1/4	17	150	17	150	20	177	22	195	25	221	26	230
1 1/2	25	221	25	221	29	257	31	274	34	301	37	328
2	33	292	33	292	42	372	46	407	49	434	55	487
2 1/2	52	460	59	522	64	566	70	620	77	681	85	752
3	85	752	94	832	105	929	117	1035	131	1159	146	1292
4	130	1150	143	1265	159	1407	176	1558	192	1699	211	1867

## CV VALUES / WEIGHT

NPS	CV	Weight (kg)	Weight (lb)
1/2	18	3.1	6.8
3/4	36	4.4	9.7
1	48	6.1	13.5
1 1/4	93	—	—
1 1/2	165	12.6	27.8
2	207	16.9	37.3
2 1/2	450	24.3	53.6
3	780	34.5	76.1
4	1360	68.6	151.3

Remark :

- 1.The torque figures at 5 bar pressure are maximum values to be tested after the valves are placed for 24 hours.
- 2.For actuator sizing, a safety factor of minimum 30% is recommended.
- 3.If the working temperature is larger than 180°C (356°F), additional safety factor of minimum 20% is recommended.

**TECHNICAL INFORMATION**



**PRESSURE - TEMPERATURE DATA**

The pressure-temperature data of ball valves is determined not only by valve shell materials but also by sealing materials used for ball seats, gland packings and flange gaskets.

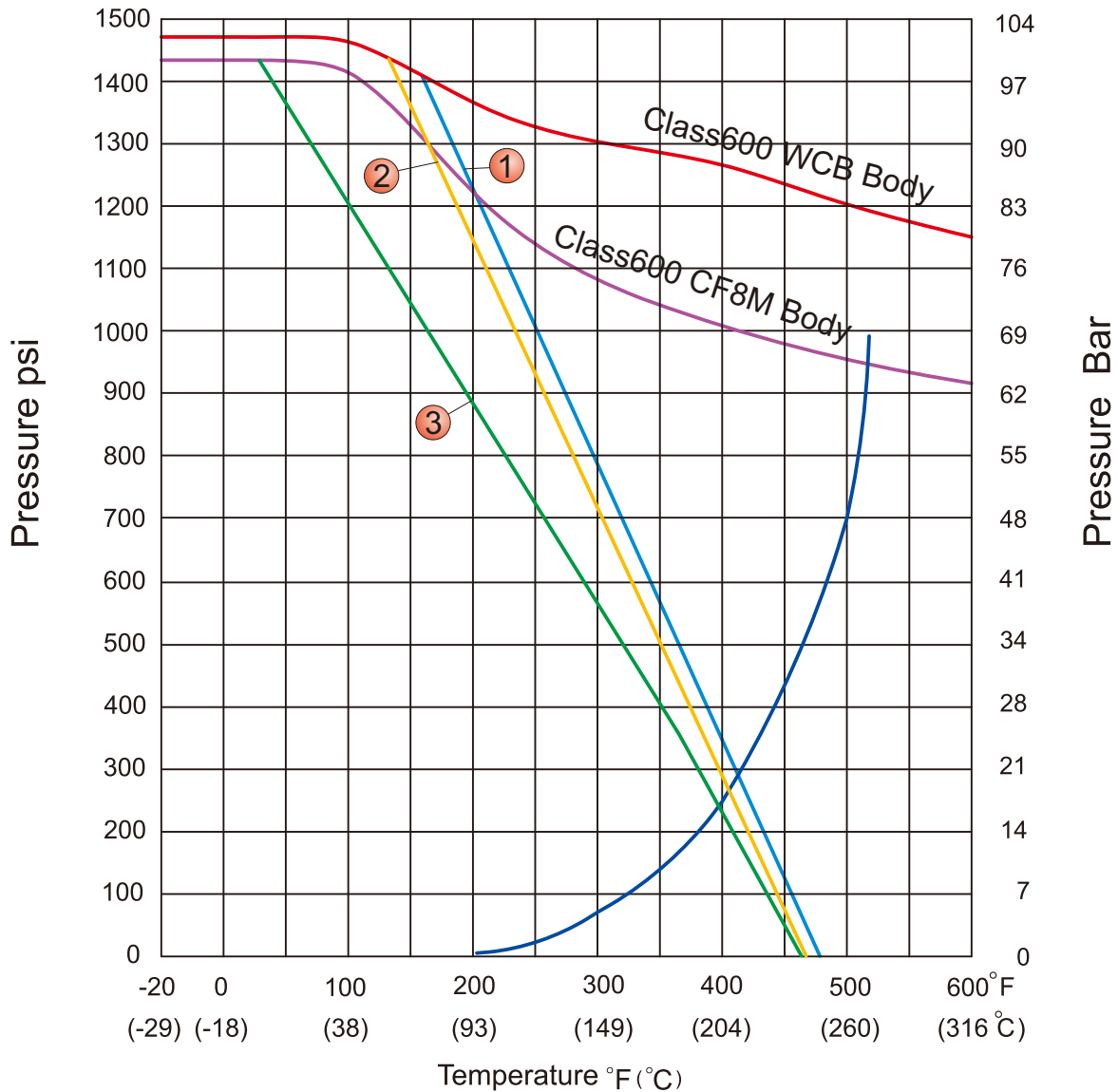

Seat Materials : TFM4215

① Full Bore : NPS ½ ~ NPS 1    ② Full Bore : NPS 1 ¼ ~ NPS 2 ½    ③ Full Bore : NPS 3 & NPS 4

Body Ratings: Shown above are for ASTM A351 Gr.CF8M and A216 Gr.WCB

For ratings of other valve shell materials, please refer to the last edition of ASME B16.34.

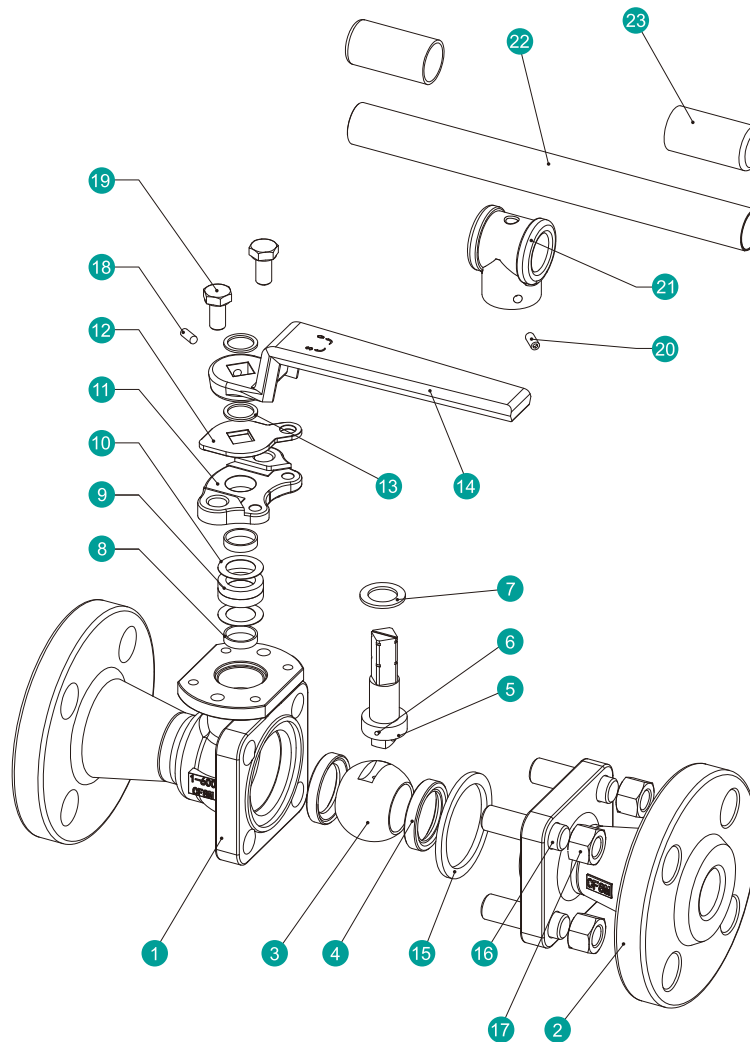
**MATERIAL OF CONSTRUCTION**

NO.	PART NAME	MATERIALS		
1	Body	A351-CF8M	A351-CF8	A216-WCB
2	Cap	A351-CF8M	A351-CF8	A216-WCB
3	Ball	A351-CF8M		
4	Ball Seat	TFM4215		
5	Stem	316	304	
6	Anti-Static	316	304	
7	Thrust Washer	PTFE/TFM1600		
8	Stem Jacket	PTFE		
9	Packing	PTFE / GRAPHITE*		
10	Bushing	316		
11	Packing Gland	CF8		
12	Triangle Stopper	304		
13	Snap Ring	304		
14	Handle (NPS 1/2 ~ 2 1/2)	WCB		
15	Body Gasket	PTFE / 316 Spiral Wound+GRAPHITE*		
16	Bolting	A193-B8	A193-B7	
17	Bolt Nut	A194-8	A194-2H	
18	Set Screwed (NPS 1/2 ~ 2 1/2)	A2-70		
19	Bolting	A2-70		
20	Set Screwed (NPS3 & NPS4)	A2-70		
21	Handle Adapter (NPS3 & NPS4)	A351-CF8		
22	Handle (NPS3 & NPS4)	A53+ZnPlated		
23	Handle Sleeve (NPS3 & NPS4)	VINYL PLASTIC		

\*Materials for KV-063 Series (Fire Safe Models)

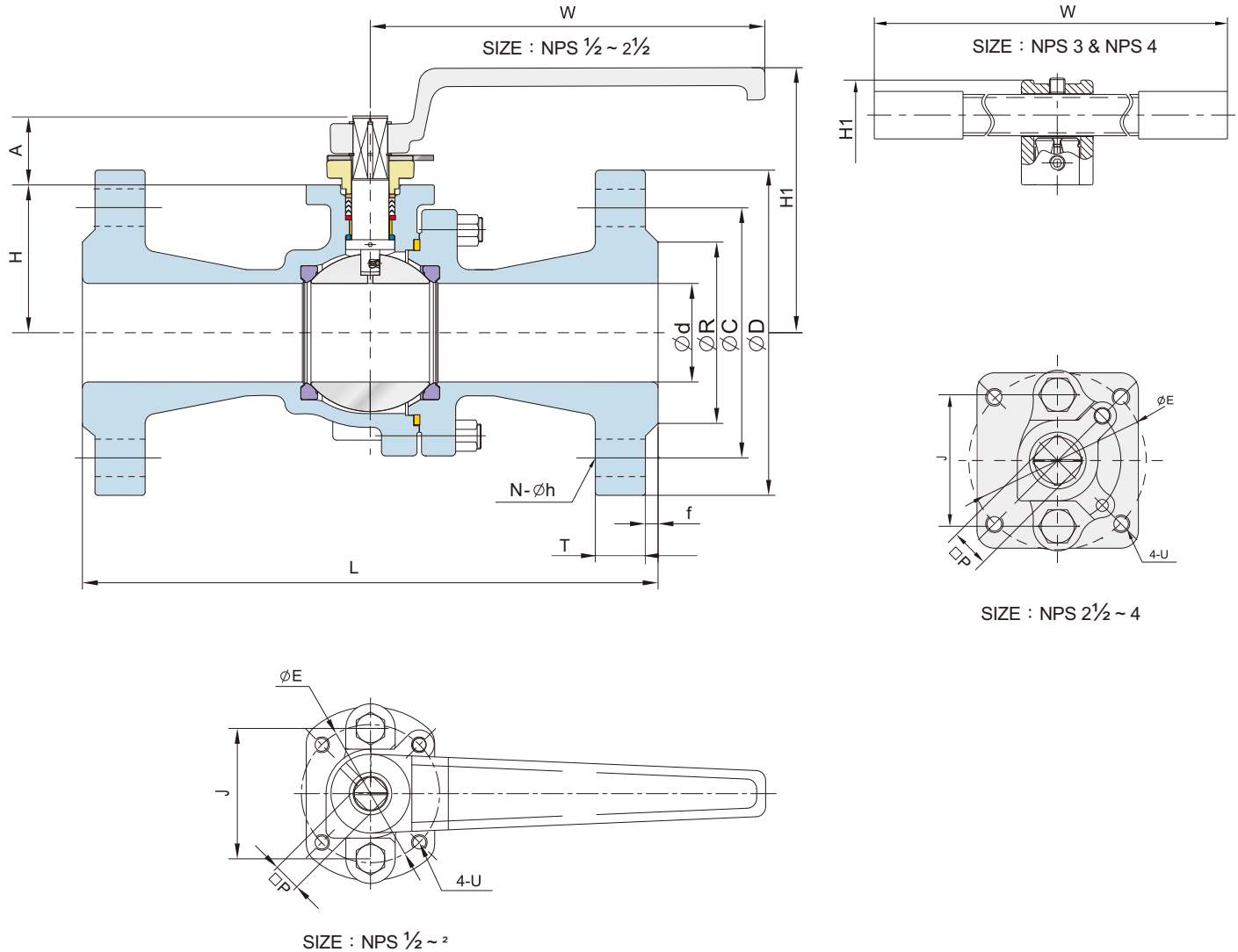

**DIMENSION TABLE**

**ASME Class 600 DIMENSION TABLE**

Unit : mm

NPS	d	L	R	D	C	f	T	H	H1	N	h	W	P	A	J	U	E	ISO 5211
1/2	15.0	165	35.0	95	66.7	7.0	14.3	39.0	89	4	16.0	130	9.0	23.2	40	M5	42	F04
3/4	20.0	190	42.9	115	82.6	7.0	15.9	46.3	96	4	19.0	130	9.0	23.2	40	M5	42	F04
1	25.0	216	50.8	125	88.9	7.0	17.5	53.0	107	4	19.0	160	11.0	27.0	50	M6	50	F05
1 1/4	32.0	229	63.5	135	98.4	7.0	20.7	59.5	115	4	19.0	160	11.0	27.0	50	M6	50	F05
1 1/2	38.0	241	73.2	155	114.3	7.0	22.3	66.0	127	4	22.2	265	14.0	34.5	66	M8	70	F07
2	50.0	292	91.9	165	127.0	7.0	25.4	77.0	136	8	19.0	265	14.0	34.5	66	M8	70	F07
2 1/2	63.5	330	104.6	190	149.2	7.0	28.6	98.5	166	8	22.2	265	17.0	50.3	75	M10	102	F10
3	76.0	356	127.0	210	168.3	7.0	31.8	108.0	206	8	22.2	400	17.0	50.3	75	M10	102	F10
4	100.0	432	157.2	275	215.9	7.0	38.1	136.0	240	8	25.4	400	22.0	55.4	75	M10	102	F10

**ASME Class 600 DIMENSION TABLE**

Unit : inch

NPS	d	L	R	D	C	f	T	H	H1	N	h	W	P	A	J	U	E	ISO 5211
1/2	0.59	6.50	1.38	3.75	2.62	0.25	0.56	1.54	3.50	4	5/8	5.12	0.354	0.91	1.57	M5	1.65	F04
3/4	0.79	7.50	1.69	4.62	3.25	0.25	0.62	1.82	3.78	4	3/4	5.12	0.354	0.91	1.57	M5	1.65	F04
1	0.98	8.50	2.01	4.88	3.50	0.25	0.69	2.09	4.21	4	3/4	6.30	0.433	1.06	1.97	M6	1.97	F05
1 1/4	1.26	9.00	2.50	5.25	3.88	0.25	0.81	2.36	4.53	4	3/4	6.30	0.433	1.06	1.97	M6	1.97	F05
1 1/2	1.50	9.50	2.88	6.12	4.50	0.25	0.88	2.60	5.00	4	7/8	10.43	0.551	1.36	2.60	M8	2.76	F07
2	1.97	11.50	3.62	6.50	5.00	0.25	1.00	3.03	5.35	8	3/4	10.43	0.551	1.36	2.60	M8	2.76	F07
2 1/2	2.50	13.00	4.12	7.50	5.88	0.25	1.12	3.90	6.54	8	7/8	10.43	0.669	1.98	2.95	M10	4.02	F10
3	2.99	14.00	5.00	8.25	6.62	0.25	1.25	4.25	8.03	8	7/8	15.75	0.669	1.98	2.95	M10	4.02	F10
4	3.94	17.00	6.19	10.75	8.50	0.25	1.50	5.35	9.45	8	1	15.75	0.866	2.18	2.95	M10	4.02	F10